

Solstice® Low GWP Refrigerants:  
**Winner of the  
Low Carbon Achievement  
of the Year**



**Long-term refrigerant solutions for commercial refrigeration**

Jean de Bernardi [jean.debernardi@honeywell.com](mailto:jean.debernardi@honeywell.com)

Technical Manager EMEA

January 2016

**Honeywell**

# Honeywell: history of innovation



**\$39-39.5B**  
in sales\*

**54%**  
sales outside U.S.

- 1,300 sites, 70 countries
- 132,000 employees
- Morristown, NJ (HQ)
- Fortune 100



**Aerospace**



**Performance Materials and Technologies**



**Automation and Control Solutions**



**Transportation Systems**



Montreal Protocol

Kyoto Protocol  
F-gas



R12

R123  
R22

404A, 410A 407C, 134a,  
**Performax (407F)**

**Solstice® family**

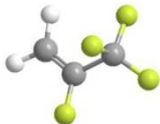

**Solstice® yf**

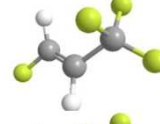

**Solstice® ze**



**Solstice® zd**





Stationary RAC



Blowing Agents



Aerosols / Solvents



MAC

\*2013 guidance

# F-Gas – Control of Use in Commercial Refrigeration Honeywell

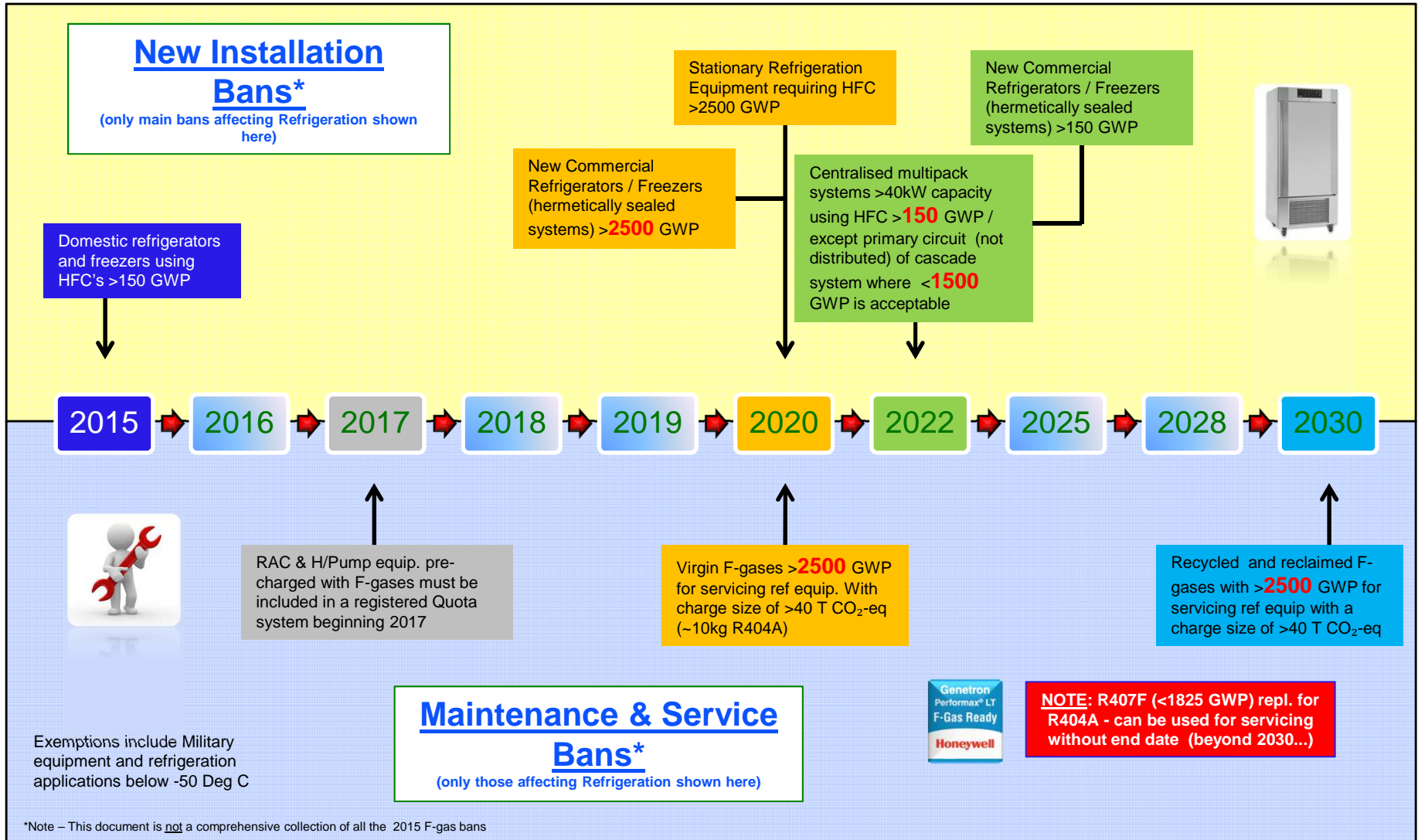

# HFC Demand – Supply forecast

Total EU HFC sales forecast in CO<sub>2</sub> equivalents  
 In million tons of CO<sub>2</sub> equivalent

- Quota
- Stock build-up
- Pre-charged imports into EU
- Total HFC demand\*\*

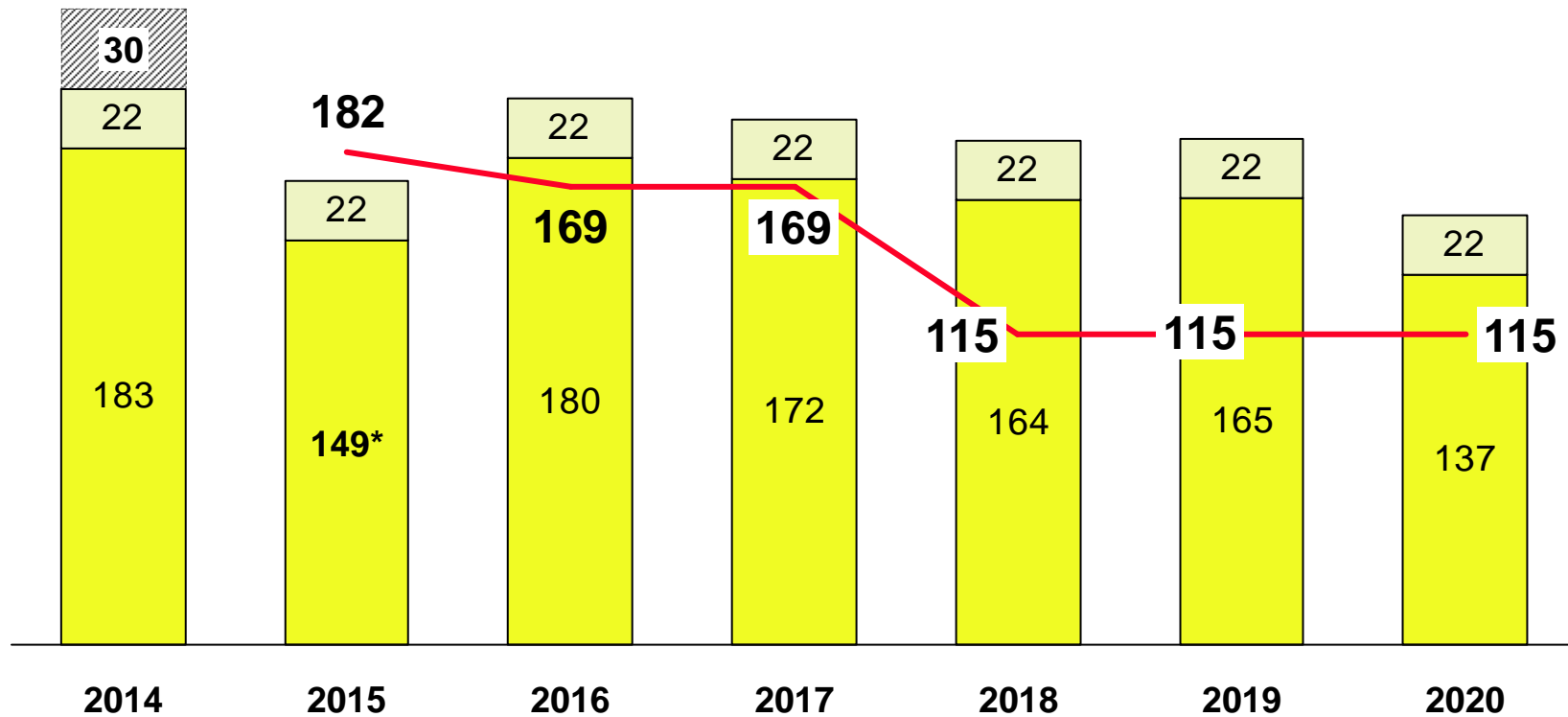

**Quota shortage expected from 2016**

\* Adjusted for inventory being built up in 2014

\*\* Also includes non reported HFCs

Source: HONEYWELL analysis, EEA technical report on fluorinated greenhouse gases

# Introduction to Solstice® family

Solstice® Low GWP Refrigerants:  
**Winner of the  
 Low Carbon Achievement  
 of the Year**



Solstice® HFO molecules Low and medium pressure applications			
	Nonflammable (ASHRAE A1)	Mildly flammable (ASHRAE A2L)	Examples of potential applications
<b>R-134a</b> GWP=1430		<b>Solstice® yf</b> GWP* < 1	Auto A/C, Vending, Refrigerators
		<b>Solstice® ze</b> GWP* < 1	Chillers, CO <sub>2</sub> Cascades Refrigerators
<b>R-123</b> GWP= 77	<b>Solstice® zd</b> GWP* =1		Centrifugal Chillers

Solstice® Blends			
	Non Flammable (ASHRAE A1)	Mildly Flammable (ASHRAE A2L)	Examples of potential applications
<b>R-134a</b> GWP=1430	<b>Solstice® N13 (R-450A)</b> GWP* = 547		Low-temp Refrigeration
<b>R-404A</b> GWP=3922	<b>Solstice® N40 (R-448A)</b> GWP* = 1273	<b>Solstice® L40X (R-455A)</b> GWP* < 150	High-temp Refrigeration
<b>R-22</b> GWP=1810	<b>Solstice® N20</b> GWP* = 891	<b>Solstice® L20 (R-444B)</b> GWP* = 295	Stationary A/C, Refrigeration
<b>R-410A</b> GWP=2088		<b>Solstice® L41 (R-447A)</b> GWP* = 572	Stationary A/C Applications



\*IPPC5



# REFRIGERATION

Genetron Performax<sup>®</sup> LT (R407F)  
Solstice<sup>®</sup> N40 (R-448A), Solstice<sup>®</sup> N13 (R-450A), Solstice<sup>®</sup> L40X (R-455A), Solstice<sup>®</sup> ze

**Honeywell**

# Genetron Performax® LT (R407F): A1, GWP=1825 for today **Honeywell**

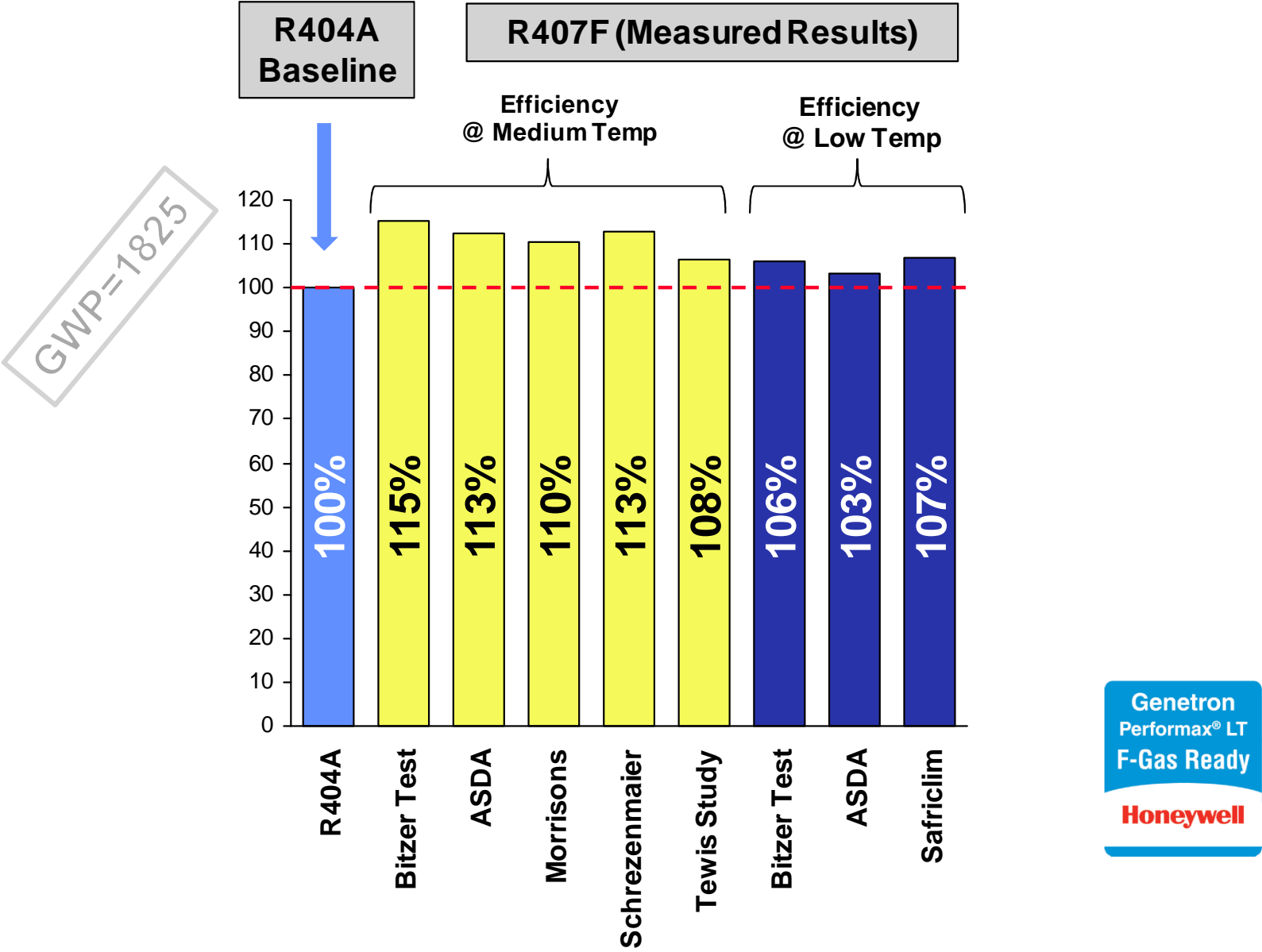

# Solstice® N40 (R-448A): A1, GWP=1273 for today

## Oak Ridge National Laboratory (US)

- Supermarket System Evaluation
  - Reduced compressor power by 3.7%
  - Increased refrigeration capacity by 7.5%
  - Increased system COP by 11.6%

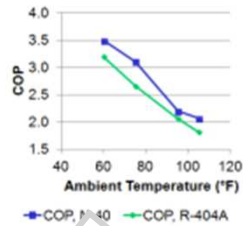

## Tewis Smart Systems

- Laboratory Test in Simulated Supermarket set-up vs R-404A

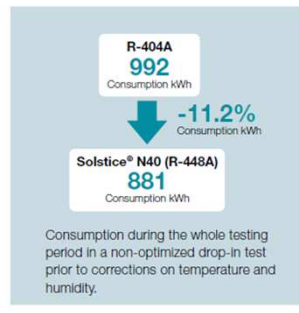

After this laboratory test, we are convinced that R-448A complements the current portfolio of alternatives for refrigeration systems by providing the lowest GWP, safest, maximum savings refrigerant for optimized characteristics in an R-404A direct retrofit.\*

## Toshiba Refrigeration (Japan)



- Condensing Unit Performance trial
  - Ambient tests at 32° & 43° C to JIS 8623 (std)
  - N40 showed COP +4-16% and excellent match in capacity

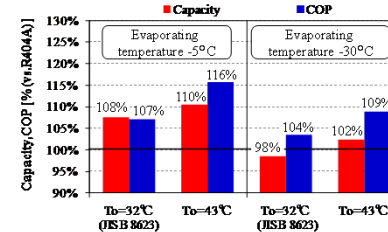

'Solstice N40 is well engineered refrigerant to meet requirement as an alternative to R404A'

GWP=1273

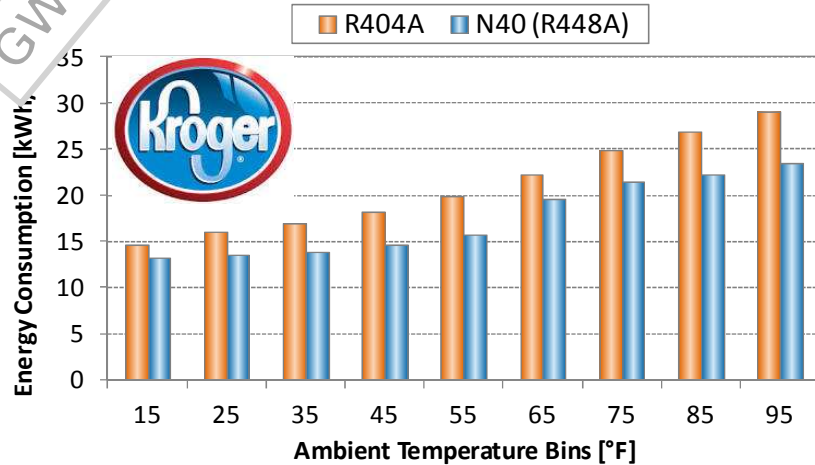

- 9-20% lower energy consumption (16% average)

## Store Trials

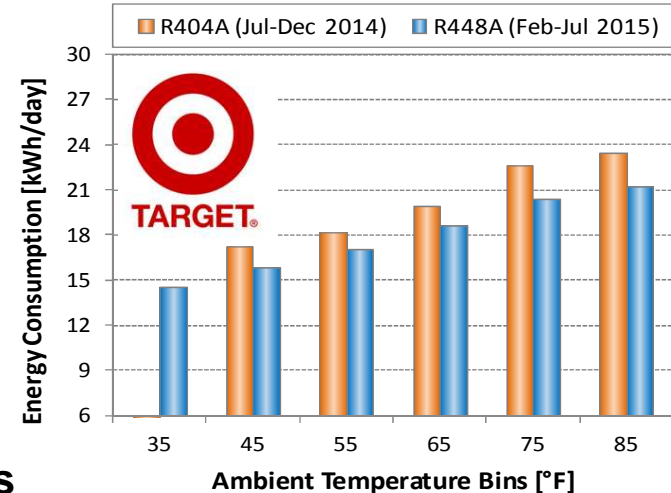

- 6-10% lower energy consumption in LT



# Solstice® N40 (R-448A): A1, GWP=1273 for today



## Scroll System Analysis @ -6.7°C / 48.9°C

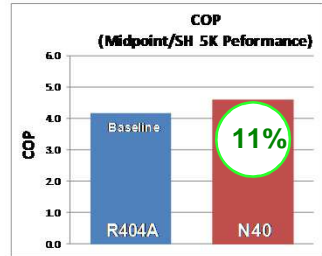
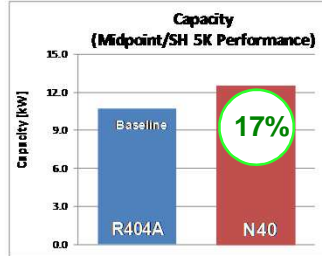

## Semi-Hermetic System Analysis @ -31.6°C / 43.3°C

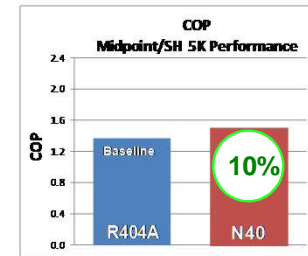
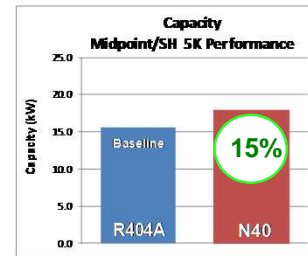

'N40 provides superior Energy Efficiency to that of R-404A with reduced GWP'

Qualified for Use

GWP=1273

## Combined\* LT and MT Energy Efficiency

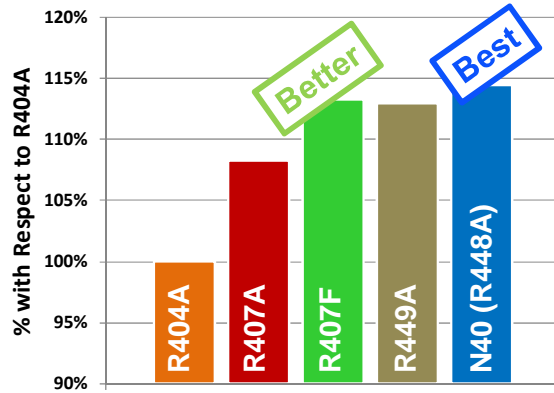

LT (-30°C) and MT (-10°C) @ 45°C Cond. Temp  
\* 33% of total load from low temp and 67% from medium temp

## Discharge Temperature

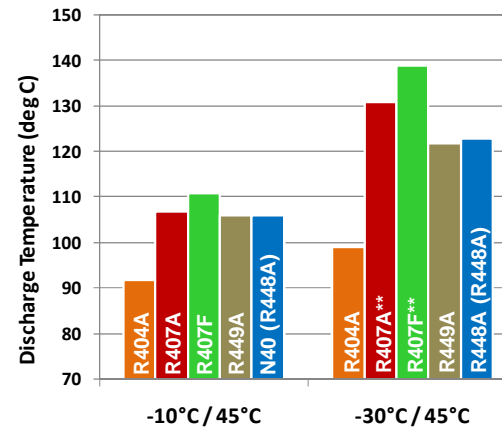

-10°C / 45°C      -30°C / 45°C  
\*\*Liquid injection required



MT

LT

# Solstice® N13 (R-450A): A1, GWP=547 for today

Honeywell

GWP=547

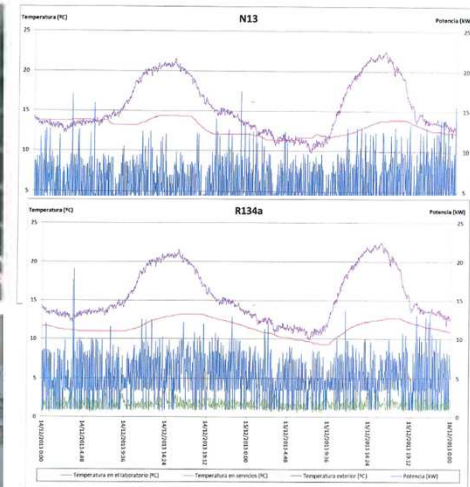
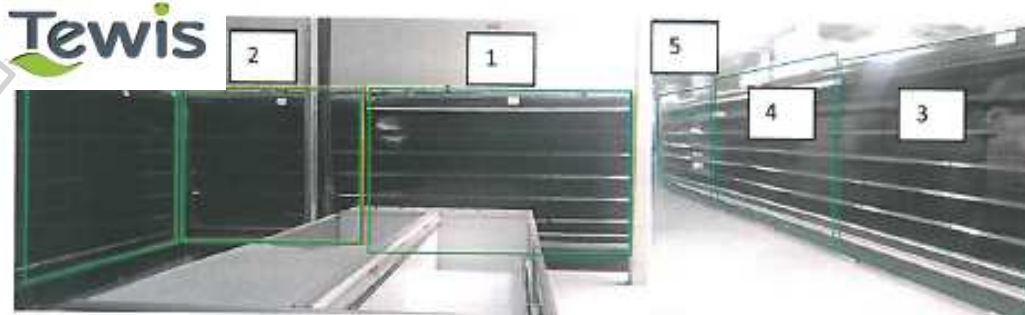

Refrigerant	Pabs (kWh)
N13 (R450A)	233.6
R134a	241.1
COP gain	+3.1%



@ -10°C/40°C (food temperature 1°C)

## Auchan Epinay (Paris): first R450A hypermarket

- 8000m<sup>2</sup>
- Commissioned October 2013
- Axima Refrigeration
- A global saving of 90 tons CO<sub>2</sub>eq / year compared with a secondary Glycol / R-134a / CO<sub>2</sub> system
- Savings of 960 tons CO<sub>2</sub>eq / year compared with using a standard R-404A DX system



# Solstice<sup>®</sup> L40X: A2L, GWP<150 for tomorrow

Honeywell

GWP<150

Solstice<sup>®</sup>L40X

	Solstice <sup>®</sup> L40X
Baseline	R-404A (A1, 3922 / 3943)
GWP 4 <sup>th</sup> / 5 <sup>th</sup>	148 / 145
Class	A2L
Potential app.	Self-contained, condensing units
Use	New
Drop-in <sup>(1)</sup> Cap.	4% lower
Drop-in <sup>(1)</sup> Eff.	3% to 6 % higher
Compressor <sup>(2)</sup>	Recip, Rotary, Scroll
Comments	Same Tdis in LT
Status	Developmental

## 1 Drop-in results (freezer)

	T <sub>evap</sub>	T <sub>disch</sub>	T <sub>cond</sub>	Q <sub>0</sub>	COP
	[°C]	[°C]	[°C]	[%]	[%]
R404A	-34.9	100	33.5	100%	100%
L40X	-34.4	108	36.1	96%	106%



## 2 Calorimeter tests on compressor (FH2511Z Mid/Mid with SH=10K)

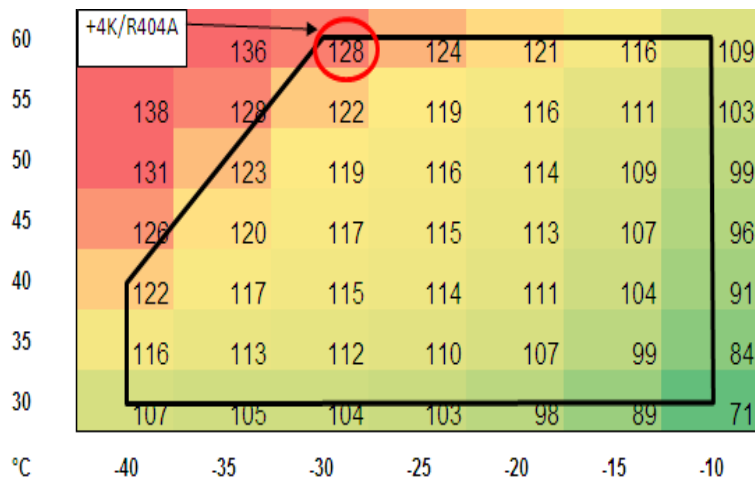

	-40	-35	-30	-25	-20	-15	-10
30	-1%	2%	5%	7%	9%	11%	12%
35	-1%	3%	6%	8%	10%	11%	12%
40	-1%	3%	7%	9%	11%	12%	13%
45		2%	7%	10%	12%	14%	15%
50		0%	6%	11%	14%	15%	17%
55			4%	10%	15%	18%	19%
60			1%	9%	16%	20%	23%

T<sub>discharge</sub> (°C)

COP vs. R404A

# Solstice<sup>®</sup>ze: A2L, GWP<1 for tomorrow

Honeywell

Solstice<sup>®</sup>ze

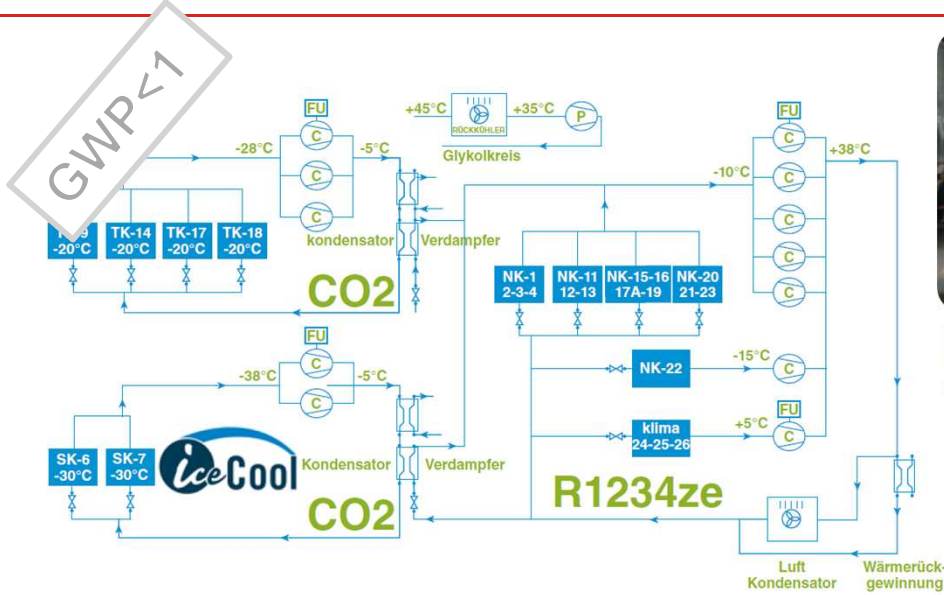

The system design was optimised to the lower pressure of Solstice ze versus the traditional refrigerant R-134a. As Solstice ze is mildly flammable, Ice Cool checked with a certified body about ATEX compliance, who assessed that given the very low risk of Solstice ze in that system design, ATEX extra measures were not needed.

## Results

- The partnership successfully delivered and implemented the first-ever Solstice ze/CO<sub>2</sub> industrial cascade system for chilling and freezing.
- Other than reducing the direct emissions by 99.9% and indirect by the improved CoP, the installation provides a future-proof solution with high safety standards.
- The refrigeration performance is very satisfactory on all different climates required for the production and offices, which guarantees the high quality required for this business

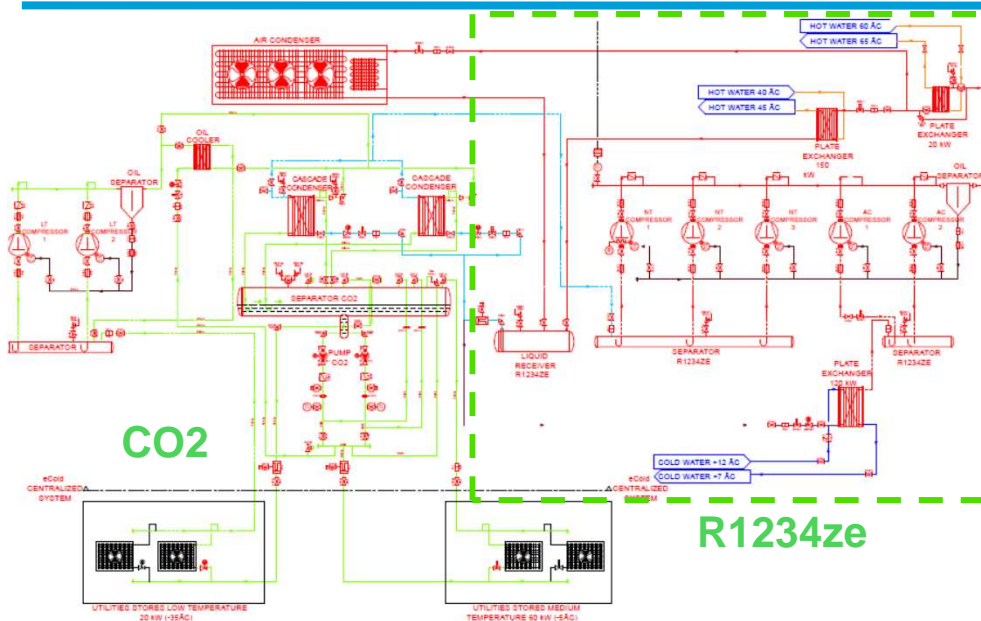

“The new cascade system in our Parma supermarket drives the entire cooling, heating and air conditioning needs of the store at reduced cost and is a template for a lower carbon and more sustainable solution for our sector. It also future-proofs our investment beyond the change in F-Gas Regulations.”

Dr. Gianfranco Iannace – Arch. Fabio Gabanella Unes/U2

## Results

- Single process solution simultaneously satisfying hot and chilled store requirements
- Reduced annual maintenance savings estimated at 15,000 Euros
- Reduced energy consumption of 45kW compared to three system architecture (refrigeration/heating/air conditioning)
- Anticipated energy savings of up to 35% over typical store set-up for cooling, heating and air conditioning



# Solstice® family

Honeywell

Solstice® Low GWP Refrigerants:  
**Winner of the  
 Low Carbon Achievement  
 of the Year**



Solstice® HFO molecules Low and medium pressure applications			
	Nonflammable (ASHRAE A1)	Mildly flammable (ASHRAE A2L)	Examples of potential applications
<b>R-134a</b> GWP=1430		<b>Solstice® yf</b> GWP* < 1	Auto A/C, Vending, Refrigerators
		<b>Solstice® ze</b> GWP* < 1	Chillers, CO <sub>2</sub> Cascades Refrigerators
<b>R-123</b> GWP= 77	<b>Solstice® zd</b> GWP* =1		Centrifugal Chillers

Solstice® Blends			
	Non Flammable (ASHRAE A1)	Mildly Flammable (ASHRAE A2L)	Examples of potential applications
<b>R-134a</b> GWP=1430	<b>Solstice® N13 (R-450A)</b> GWP* = 547		Low-temp Refrigeration
<b>R-404A</b> GWP=3922	<b>Solstice® N40 (R-448A)</b> GWP* = 1273	<b>Solstice® L40X (R-455A)</b> GWP* < 150	High-temp Refrigeration
<b>R-22</b> GWP=1810	<b>Solstice® N20</b> GWP* = 891	<b>Solstice® L20 (R-444B)</b> GWP* = 295	Stationary A/C, Refrigeration
<b>R-410A</b> GWP=2088		<b>Solstice® L41 (R-447A)</b> GWP* = 572	Stationary A/C Applications



\*IPPC5

# Merci ! Questions?

**Honeywell**



# Honeywell



[www.honeywell.com](http://www.honeywell.com)



**DISCLAIMER**

Although all statements and information contained herein are believed to be accurate and reliable, they are presented without guarantee or warranty of any kind, expressed or implied. Information provided herein does not relieve the user from the responsibility of carrying out its own tests and experiments, and the user assumes all risks and liability for use of the information and results obtained. Statements or suggestions concerning the use of materials and processes are made without representation or warranty that any such use is free of patent infringement and are not recommendations to infringe on any patents. The user should not assume that all toxicity data and safety measures are indicated herein or that other measures may not be required.